

# Application Note

## Choosing the right Pico Technology active differential probe

Pico Technology offers many active differential probes covering a wide range of voltages, category (CAT) ratings and bandwidths. As the name suggests, these probes have two major features:

- **Active:** Active probes achieve low input capacitance and high sensitivity by buffering and amplifying the signal close to the point of measurement.
- **Differential:** Differential probes present two non-grounded terminals for connection to the measurement and can thus measure accurately without directly connecting one test node to ground or drawing significant current from either test node.

This ability to measure without a low-impedance connection improves safety when measuring high voltages or in the presence of high voltages.

Before we look at choosing the correct probe for your application, let's go back a step and explain why you would want to use a differential probe.



## Choosing the right Pico Technology active differential probe

### 1. The problem: signal with unwanted common-mode noise

Consider the circuit below. It consists of a signal source (purple) with AC and DC components producing a total output of  $V_{SIG}$ , which is the signal we wish to measure. In addition, the circuit contains an unwanted voltage source (green) that also has AC and DC components adding up to  $V_{CM}$ .  $V_{CM}$  stands for common-mode voltage, which means a signal that is added equally to both measurement terminals.

As the following diagram shows, viewing the output and ground terminals with a single-ended probe would result in a distorted waveform ( $V_{SUM}$ ) on the display. We cannot solve this by connecting the probe ground to the negative terminal of  $V_{SIG}$ , as that would short-circuit  $V_{CM}$  to ground through the oscilloscope and possibly cause a damaging current to flow. We need a probe that can safely detect  $V_{SIG}$  and ignore  $V_{CM}$ .

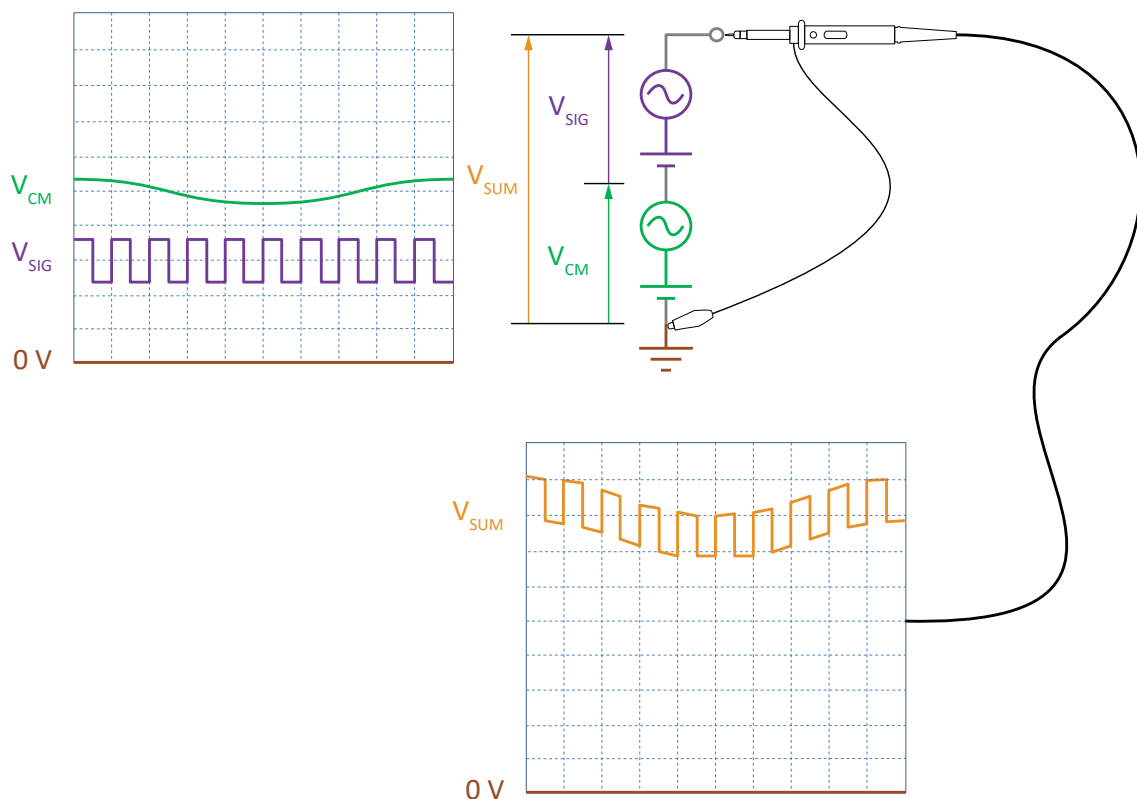

Figure 1 - Using a single-ended oscilloscope probe

# Application Note

## Choosing the right Pico Technology active differential probe

### 2. The solution: an active differential probe

The solution, as shown below, is to connect a differential probe across the positive and negative terminals of the signal source. The probe does not measure the common-mode voltage  $V_{CM}$ , only the signal of interest  $V_{SIG}$ , so  $V_{SIG}$  is what you see on the oscilloscope display.

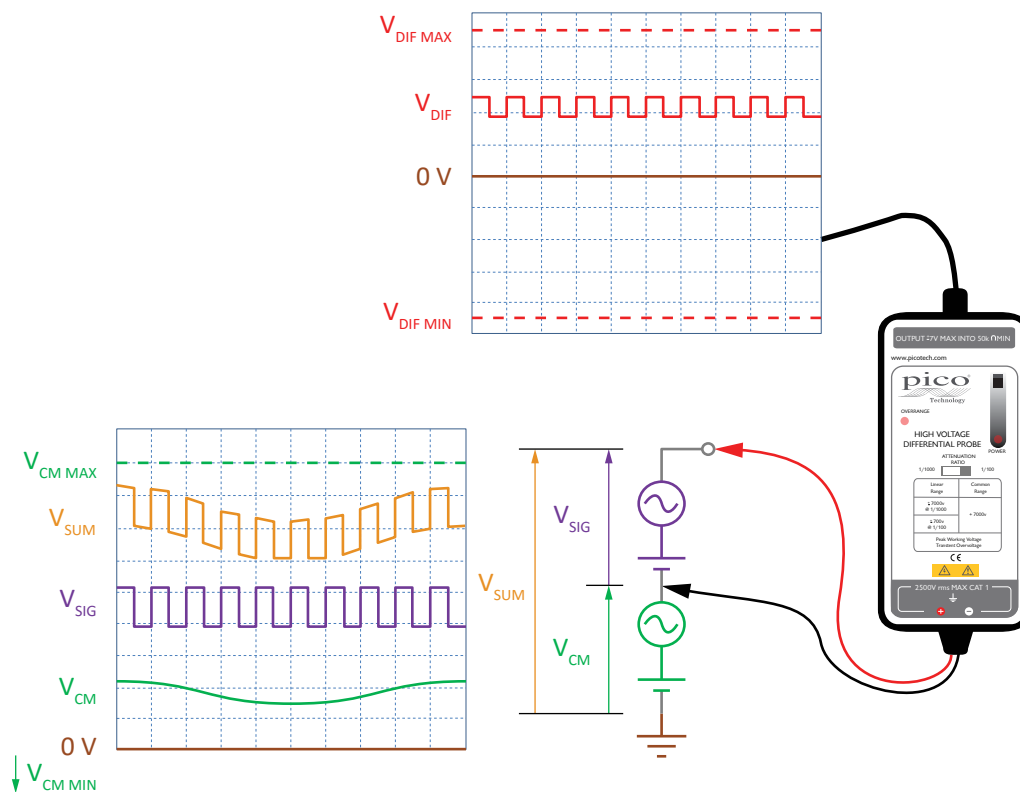

Figure 2 - Using an active differential probe

Differential probes can measure the AC or DC voltage between two points connected to the positive and negative leads with neither of the points being grounded. This enables the probes to take measurements where single-ended probes can't, for example at voltages that are much higher than ground potential, and the resulting measurements focus exclusively on the potential difference between the probes.

A differential probe must always be operated within its voltage limits. These are explained under Input ranges below.

### 3. Using the probe for single-ended measurements

An often overlooked fact is that the active differential probe excels at making single-ended measurements when compared to a passive single-ended probe. The rejection of common-mode voltages and low capacitance result in real measurement advantages such as lower noise and lower circuit loading. To make a single-ended measurement, the positive input lead is connected as normal to the signal and the negative input lead is connected to ground.

# Application Note

## Choosing the right Pico Technology active differential probe

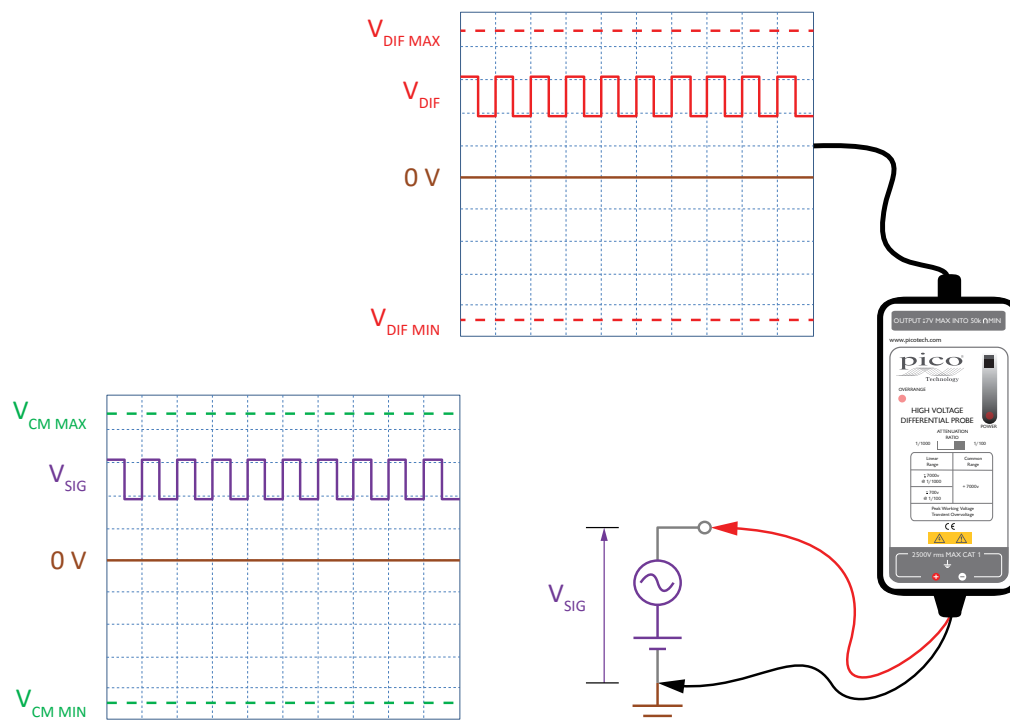

Figure 3 - Single-ended measurement

### 4. Bandwidth

The quoted bandwidth tells you the maximum rise time of the signal that the instrument or probe can accurately measure. In other words, a 25 MHz oscilloscope or probe will allow frequencies below 25 MHz and reject all above. It will show a 25 MHz sine wave, although with up to 3 dB amplitude error. If your signal is a 25 MHz square wave the rise time is much faster, and you will need higher bandwidth in order to measure or display the waveform correctly. The common rule of thumb for selecting a product of the correct bandwidth is:

$$\text{bandwidth (Hz)} = \frac{0.35}{\text{rise time (s)}}$$

You must also consider the combined rise time of both the oscilloscope and the probe. The combined rise time  $t_{RC}$  of two devices with individual rise times  $t_{R1}$  and  $t_{R2}$  is given by:

$$t_{RC} = \sqrt{t_{R1}^2 + t_{R2}^2}$$

This is equivalent to combining the bandwidth of the oscilloscope and the probe. Use the two equations above to find the combined bandwidth of the two devices.

## Choosing the right Pico Technology active differential probe

High-voltage measurements often contain fast impulses (transients) that have very fast rise times. To measure or display these accurately, the combined bandwidth of the probe and the oscilloscope must be several times higher than the fundamental frequency.

Our active differential probes and oscilloscopes range in bandwidth from 25 MHz to 800 MHz. Not all are high-voltage instruments so check the specifications carefully.

### 5. Input ranges

There are three main ranges you will see in the active differential probe specifications: the differential mode range, common-mode range and absolute maximum range. The first two refer to the maximum measurable voltage levels, which depend on the application. The third is the maximum constant non-destructive voltage that can be applied, not including any transient overvoltage that the probe can withstand. Let's look closer:

#### 5.1 Differential-mode range

This is the maximum measurable range between the two differential test prods. It is stated as "DC+AC Peak" and "V RMS", because some elements of the probe design are stressed by voltage peaks and others by continuous dissipated power. You must calculate both for every application and ensure that neither exceeds the probe's specification.

Active differential probes often have switch-selectable attenuation, with the higher voltage probes having up to 1:100 and 1:1000 times attenuation. Each attenuation setting has its own differential-mode range. The Pico Technology range of active differential probes starts from  $\pm 15$  V DC+AC peak with no switchable attenuation, to  $\pm 700$  /  $\pm 7000$  V DC+AC peak (5000 V RMS) equipped with switchable attenuation.

#### 5.2 Common-mode range

The common-mode range is the maximum voltage that can be measured on either input with respect to ground. Care must be taken when measuring signals with high common-mode voltages because active probes reject the common-mode signal so that it is not displayed on the oscilloscope screen. To check that you are not exceeding the common-mode range, you may need to make separate measurements of each terminal relative to ground using the active differential probe in single-ended mode or a separate high-voltage single-ended probe. As with differential mode ranges, each attenuation setting has its own common-mode range.

When determining the suitability of the probe for your application, take care that neither common-mode nor differential range exceeds the specifications. For a non-CAT-rated probe (see below for an explanation of CAT ratings), take care to include any transient voltages in your measurement range.

#### 5.3 Absolute maximum voltage

This is the highest constant voltage that the probe can withstand without being damaged. It is not to be confused with the transient protection defined in the CAT rating system. Some probes have very little headroom between the maximum measurable voltage and the absolute maximum voltage, so care must be taken not to overload the probe.

## Choosing the right Pico Technology active differential probe

Probes without a CAT rating often have no specified transient protection. In this case you must include any transients in the maximum measurable range or risk damage to the probe, other equipment or yourself.

### 6. Common-mode rejection ratio

Having established that the probe has sufficient common-mode range at DC, you must also ensure that any common-mode noise or signal does not feed into your measurements. Common-mode noise can be caused by electromagnetic interference coupled into the input leads, and by noise and surges in the ground of the device under test (DUT) relative to the ground of the oscilloscope. Connecting the grounds of the oscilloscope and the DUT helps to minimize these noise voltages.

Common-mode rejection ratio (CMRR) is a measure of the voltage disturbance on the probe's output relative to the common-mode voltage on the inputs. The higher the CMRR, the better the probe is isolated from common-mode interference.

For example, you might know that there is 1 volt of noise on the ground of the DUT. The probe's specification says that CMRR is 100:1. The result is that on the output you could see common-mode noise of up to 10 mV referred to the inputs. CMRR tends to be highest at DC and then decline as the frequency of the common-mode signal increases.

### 7. Voltage derating

The specified absolute maximum voltage for a probe input is valid only at DC and low AC frequencies. Above a certain frequency, the voltage rating starts to drop. This effect, called "derating", is generally specified in the form of a graph of voltage against frequency.

In the example above, the absolute maximum voltage on either of the inputs at low frequencies is 1000 V RMS. At about 3.3 MHz the voltage starts to decline, until at about 25 MHz it is only 150 V RMS. In practice this is seldom a limitation as high frequency and high voltage are rarely found together – such signals being more challenging to generate than they are to measure.

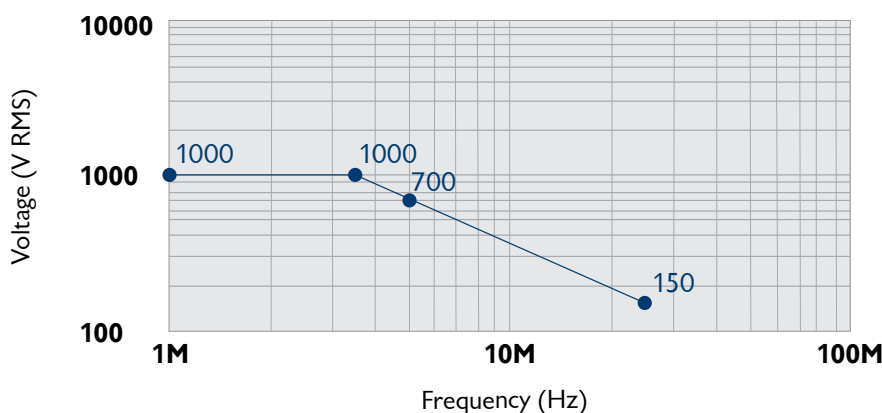

When using the probe at high frequencies, be sure to consider voltage derating as exceeding the derated voltage could damage the probe.

## Choosing the right Pico Technology active differential probe

### 8. Input resistance

The input resistance of the probe is measured between its differential inputs. When you connect the probe to the DUT, you are effectively connecting each test point through a high-value resistor and a small capacitor to ground, thereby creating a path between the two inputs through ground. This will cause some differential current to flow between the two inputs and from each input to ground. However small these currents, they may disturb the circuit under test, so you must consider whether this will significantly affect the accuracy of your measurement. The effect is worse when measuring high-impedance circuits.

### 9. Safety and the IEC 61010-031 category (CAT) rating system

We can't emphasize enough that safe working with electrical test accessories requires competency in the systems being worked on and electrical systems knowledge. You need training before flying a plane, so why would you use electrical test equipment without technical know-how?

User safety is paramount when measuring mains voltages. The category rating system has been designed to protect you from the sometimes unpredictable nature of high-energy impulses (transients) resulting from, for example, grid or load faults. The risk to life and safety from lightning strikes, transients and surges depends on the where within the mains supply path you are doing the testing. Categories are related to the amount of energy in an impulse, not just the peak voltage it reaches. Expertise is required to correctly identify the measurement category and to select the appropriately rated instruments and accessories to make the measurement safely.

Three measurement categories are defined in IEC 61010-031 (or your equivalent national product safety standard, which may have a different prefix in place of the "IEC"), from CAT II up to CAT IV. The higher the rating, the more demanding is the safety requirement for that measurement accessory. In other words, the higher the CAT rating, the more energetic are the transients that the device must withstand and protect the user against. Products without a CAT rating cannot be used on mains installations and so generally have no transient rating. It is important to note that IEC 61010-031 applies only to low-voltage test equipment rated up to 1000 V.

#### 9.1 CAT II

For measurements performed on circuits directly connected to outlets of the low-voltage installation. There should be at least three levels of overcurrent protection between these circuits and the supply transformer.

Examples: measurements of the mains-supply nodes in household appliances, portable tools and similar equipment.

#### 9.2 CAT III

For measurements performed on the distribution part of a building's low-voltage mains installation. There should be at least two levels of overcurrent protection between these points and the supply transformer.

Examples: measurements on distribution boards, circuit-breakers, wiring, including cables, bus-bars, junction boxes, switches, socket-outlets in the fixed installation, and equipment for industrial use and some other equipment, for example, stationary motors with permanent connection to the fixed installation.

## Choosing the right Pico Technology active differential probe

### 9.3 CAT IV

For measurements performed at the source of a building's low-voltage installation. There should be at least one level of overcurrent protection between these points and the supply transformer.

Examples: electricity meters and measurements on primary overcurrent protection devices and ripple control units.

### 9.4 Equipment without a rated measurement category (called CAT I on older measurement devices)

For measurements performed on circuits not directly connected to a mains supply.

Examples: specially protected (internal) circuits derived from a mains supply, telephones, vehicle electrics.

### 9.5 Working voltages

The table below shows that within each category there are predefined working voltages of 50 V, 100 V, 150 V, 300 V, 600 V and 1000 V. The higher the voltage in the given category, the higher the level of protection required. There is no transient protection recommendation for measurements below CAT II.

| Rated voltage | Voltage transients |         |         |
|---------------|--------------------|---------|---------|
|               | CAT II             | CAT III | CAT IV  |
| 50 V          | 520 V              | 806 V   | 1.55 kV |
| 100 V         | 806 V              | 1.55 kV | 2.55 kV |
| 150 V         | 1.55 kV            | 2.55 kV | 4.07 kV |
| 300 V         | 2.55 kV            | 4.07 kV | 6.1 kV  |
| 600 V         | 4.07 kV            | 6.1 kV  | 7.8 kV  |
| 1000 V        | 6.1 kV             | 7.8 kV  | 12.1 kV |

Table 1. IEC-61010-031 categories and their associated transient voltages

Pico Technology does not offer probes suitable for making measurements in CAT IV areas, so for the purposes of choosing a Pico differential probe this article discusses probes only up to CAT III.

### 9.6 Choosing the right category rating for your application

All measurement accessories fit for use on category rated test circuits have a CAT rating marking. Our active differential probes have the category rating and its associated Rated voltage (refer to table above) clearly marked on the probe and in the specification. Take the CAT II 1000 V rated probe for example: although its transient protection voltage (6.1 kV) is the same as that of a CAT III 600 V rated probe, the two probes are not equivalent. Each probe is designed for the CAT rating as labelled and no higher.

Some probes may have higher rated test prods than the rating marked on the probe. The TA044, for example, is a CAT I probe with 1000 V CAT III test prods. This does NOT make it suitable for CAT III use. Think of the 1000 V CAT III prods as the only thing between you and a potential arc flash, so having higher-rated test prods is just another safety net. The CAT III prods are designed with higher insulation, creepage and clearance distances.



# Application Note







## Choosing the right Pico Technology active differential probe

The test prods fitted are removable and replaceable. Fused prods are compulsory for making CAT III measurements.

We repeat our earlier advice that, if you are in doubt about the suitability and safety of any active differential probe in your application, you must consult a qualified engineer. Pico Technology technical support will be pleased to advise you.

**For more information please visit:**

<https://www.picotech.com/accessories/active-oscilloscope-probes>

| Product highlights  |  |
|---|--|
|    | 100 MHz 1400 V differential oscilloscope probe 100:1/1000:1<br>TA042<br><a href="#">VIEW ITEM &gt;</a> |
|  | 100 MHz 700 V differential oscilloscope probe 10:1/100:1<br>TA043<br><a href="#">VIEW ITEM &gt;</a>    |
|  | 200 MHz 20 V differential oscilloscope probe 10:1<br>TA045<br><a href="#">VIEW ITEM &gt;</a>           |
|  | 25 MHz 1400 V differential oscilloscope probe 20:1/200:1<br>TA057<br><a href="#">VIEW ITEM &gt;</a>    |
|  | 25 MHz 700 V differential oscilloscope probe 10:1/100:1<br>TA041<br><a href="#">VIEW ITEM &gt;</a>     |

Pico Technology  
James House  
Colmworth Business Park  
ST. NEOTS  
PE19 8YP  
United Kingdom

☎ +44 (0) 1480 396395  
☎ +44 (0) 1480 396296  
✉ [sales@picotech.com](mailto:sales@picotech.com)

Pico Technology  
320 N Glenwood Blvd  
Tyler  
Texas 75702  
United States

☎ +1 800 591 2796  
☎ +1 620 272 0981  
✉ [sales@picotech.com](mailto:sales@picotech.com)



THE QUEEN'S AWARDS  
FOR ENTERPRISE:  
INTERNATIONAL TRADE  
2014



**SISTEMI** [www.pcbtech.it](http://www.pcbtech.it)  
**STRUMENTI** [www.epcb.it](http://www.epcb.it)

Viale Beniamino Gigli, 15  
60044 Fabriano AN  
[info@pcbtech.it](mailto:info@pcbtech.it)

Tel. +39 0732 250458  
Fax +39 0732 249253  
C.F. / P.I. 01474230420