

# Probe positioning system

## User's Guide



### Introduction

This probe positioning system holds your printed circuit board (PCB) during soldering, inspection and test, and includes probe holders for Pico 2.5 mm oscilloscope probes.

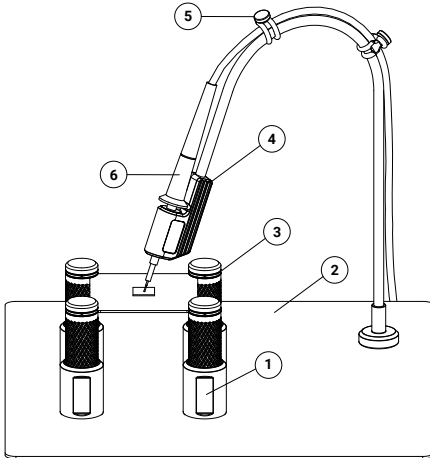

1. Spring-loaded magnetic PCB holder (4)
2. Base plate (210 x 297 mm)
3. Insulation washer, blue
4. Magnetic 2.5 mm oscilloscope probe holder (4)
5. Cable holders, supplied in channel identification colors A to D and E to H
6. Oscilloscope probe

### Kit contents

	PQ215 4-channel kit (without probes)	PQ216 4-channel kit with 300 MHz probes	PQ217 4-channel kit with 500 MHz probes	PQ219 8-channel kit with 4 probes <sup>1</sup>	PQ218 4 additional probe holders
PCB holders	4	4	4	4	
Base plate (210 x 297 mm)	1	1	1	1	
Insulation washers, set of 10	1	1	1	1	
2.5 mm probe holder	4	4	4	8	4
Cable holder set, channels A-D	1	1	1	1	1
Cable holder set, channels E-H	1	1	1	1	1
P2056 500 MHz 10:1 passive probe			4	4	
P2036 300 MHz 10:1 passive probe		4			

<sup>1</sup> Adds four probes to the four already supplied with your 8-channel PicoScope 6824E or 6804E and also adds eight probe holders.

## Instructions for use

### Insulation washer installation

A set of ten self-adhesive insulation washers is supplied and they should be mounted on each PCB holder. They add extra insulation during measurements. Do not use the washers in environments above 85 °C (185 °F). Follow the steps below to install the washers:

1. Pull the spring-loaded knurled sleeve of the PCB holder downwards. Open the slot in the washer slightly and slide it around the pin, ensuring that the adhesive side contacts the lower aluminum surface.
2. Repeat for the upper side.
3. Upper and lower washers shown installed correctly.
4. Release the knurled sleeve.

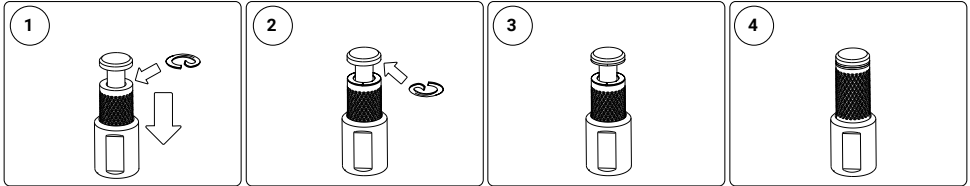

### Operating instructions

To position the PCB holder: Remove the protective plastic film from the base plate. Then, place the holder on the base plate and the magnet will keep it secure.

To reposition the holder: A low-friction surface allows you to slide the holder across the base plate.

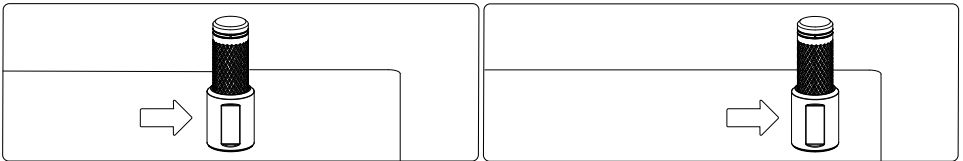

### Holding a circuit board

1. Pull the spring-loaded knurled sleeve downwards and insert the circuit board.
2. Gently release the sleeve to fix the circuit board in place.
3. Position the required number of holders around the circuit board. Make sure the holders are evenly distributed around the board.

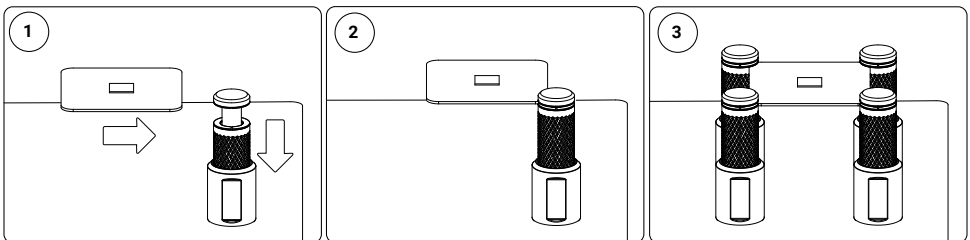

## Installing and holding a probe

1. Place the probe holder onto the magnetic base
2. Insert the probe into the probe holder
3. Push the probe into place so that it fits into the groove in the holder
4. Secure the probe wire to the flexible support with the colored cable holders provided. Use colors associated with the probing channel in use to assist channel identification.

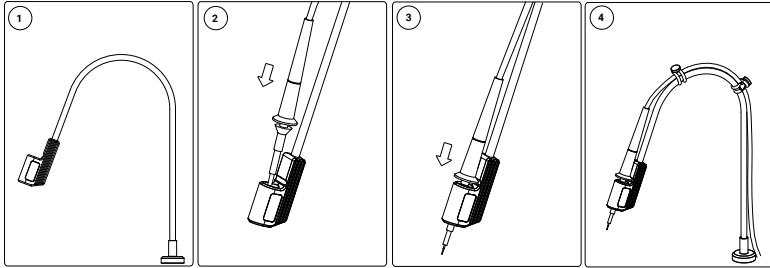

### CAUTION

Take care when operating the spring-loaded sleeve on the PCB holder and when placing the magnetic holders on the base plate as they may create pinch hazards.

### WARNING

The magnets supplied in this kit have strong magnetic fields. Users of pacemakers and insulin pumps must avoid using these items.

## Warranty and returns

This product is supplied with a one-year return-to-manufacturer warranty against defects in material and workmanship. Visit [picotech.com/about](http://picotech.com/about) for more information.

**United Kingdom  
global headquarters**

Pico Technology  
James House  
Colmworth Business Park  
St. Neots  
Cambridgeshire  
PE19 8YP  
United Kingdom

Tel: +44 (0)1480 396 395

[sales@picotech.com](mailto:sales@picotech.com)  
[support@picotech.com](mailto:support@picotech.com)

[www.picotech.com](http://www.picotech.com)

**North America regional office**

Pico Technology  
320 N Glenwood Blvd  
Tyler  
TX 75702  
United States

Tel: +1 800 591 2796 (toll free)

[sales@picotech.com](mailto:sales@picotech.com)

**Asia-Pacific regional office**

Pico Technology  
Room 2252, 22/F, Centro  
568 Hengfeng Road  
Zhabei District  
Shanghai 200070  
PR China

Tel: +86 (0) 21 2226-5152

[pico.asia-pacific@picotech.com](mailto:pico.asia-pacific@picotech.com)